

MOTORS PRICE LIST

LP39 Rev. 01 w.e.f. 26th Sept 2019

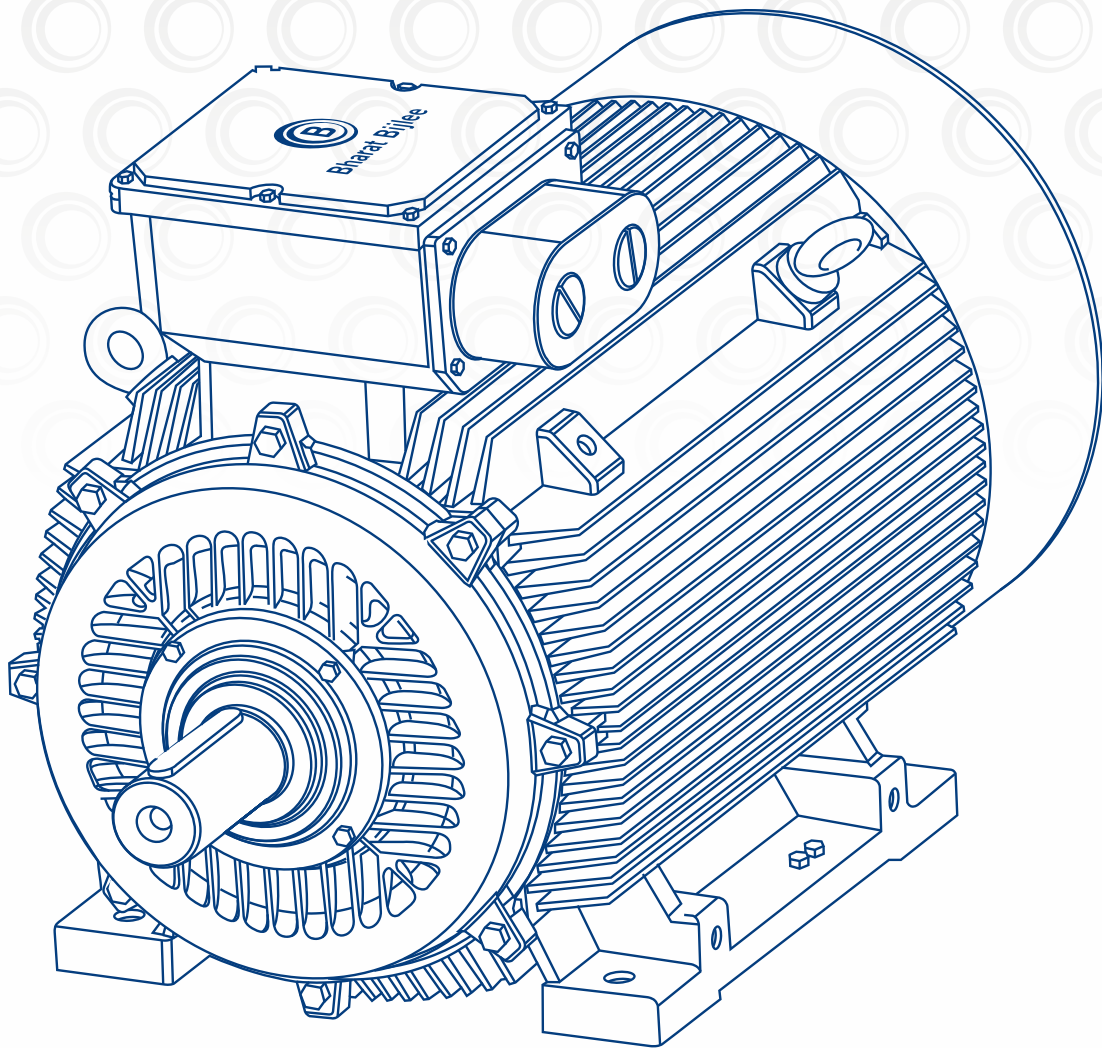

A MOTOR FOR EVERY NEED

MOTORS PRODUCT RANGE



General Purpose Motors for Safe Area

- IE2 series
- Premium Efficiency IE3 series motors



Hazardous Area Motors

- Flame Proof Motors Ex(d) in IE2 & IE3 efficiencies
- Non-Sparking Motors Ex(nA) in IE2 efficiency



Special Purpose Motors

- Brake Motors
- Crane & Hoist Duty Motors
- Slip Ring Motors
- Cane Unloader Motors
- Textile Motors



High Efficiency Large Frame Motors with DCCA

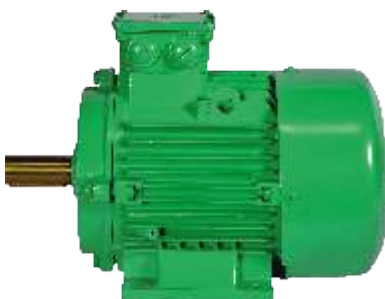

SynchroVERT®

IE4 Super Premium Efficiency Motors

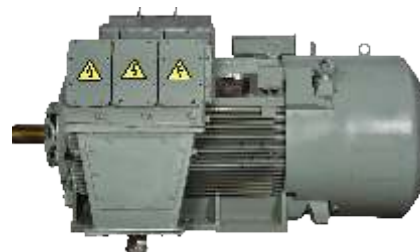

MV Motors upto 1000 kW

- Safe Area Motors: upto 11kV
- Non Sparking Motors Ex(nA): upto 6.6kV

CONTENT

LV Motors: An Introduction	1
Safe Area Motors	2
IE2 Series Safe Area Motors	2-3
IE3 Series Safe Area Motors	4-5
Flame Proof Motors: Type Ex(d)	6
FLP Motors: Standard Range	6
FLP Motors: Efficiency Values Complying to IE2 Class	7-8
FLP Motors: Efficiency Values Complying to IE3 Class	9-10
Special Purpose Motors	11
Crane & Hoist Duty Motors	11
Crane Duty Slip Ring Motors	12
Cash Extras for Additional Features	13-19

LV MOTORS: AN INTRODUCTION

The 18th century saw the advent of various technologies that led to the Industrial Revolution. Machines started replacing manual labour with an intent to increase productivity. Today, we are in a world where technology is advancing at an unprecedented rate and the backbone of this advancement is the most reliable and sustainable set of drivers. As one of the emerging nations, India is progressively adopting technologies and systems that guarantee the next level of performance. Electric motors are the prime movers for a large part of industry. It is hence imperative to have the most efficient and reliable motors to drive all possible applications.

With a continuous endeavor towards innovation and customer centricity, Bharat Bijlee since 1946 has developed a wide range of motors to suit various applications. Adherence to stringent quality norms in our manufacturing process ensures successful operation of our motors during their lifespan. With an in-house design team and state-of-the-art manufacturing facility, we have developed the skill, expertise and competence to manufacture highly customized motors and also for the most severe of applications. Owing to our emphasis on customer satisfaction in all aspects of product and service, we are the most trusted brand in the industry.

Why Bharat Bijlee?



Preferred brand across various sectors viz cement, construction, steel, food and beverages, water and wastewater, sugar, distilleries, paper, oil and gas, mining, power, chemical



Most stable operation on all applications (illustration depicted below)



Track record of over 4 million motors working successfully in the industry



The most suitable solutions to extremely harsh and severe applications



Customized motors designed and manufactured to suit application specific needs



Motors conform to relevant IS/IEC standards and other statutory requirements

The manufacturing facility for our entire portfolio is located across a 1,70,000 sq. metres campus in Airoli, Navi Mumbai. This is supported by an extensive sales and service network across the country and a central ServiceLINE™ desk.

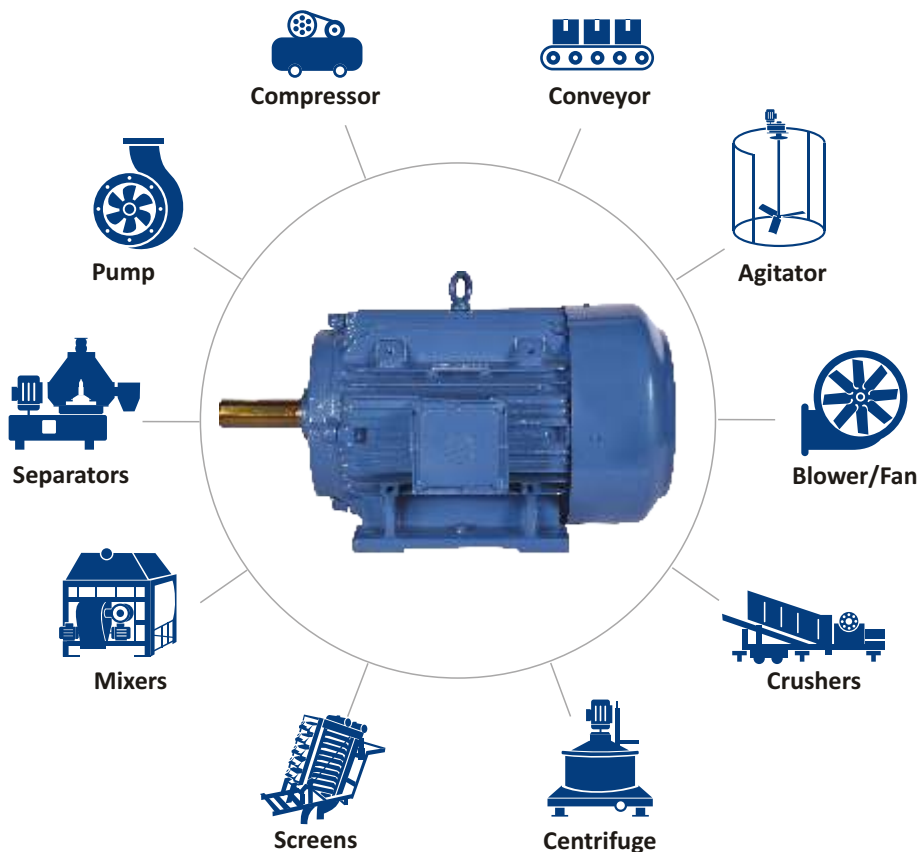

IE2 SERIES SAFE AREA MOTORS

Foot mounted (B3 construction) 3 Phase Squirrel Cage Induction Motors suitable for 415V $\pm 10\%$, 50Hz $\pm 5\%$,

Combined Variation $\pm 10\%$, Insulation Class F, with temperature rise limited to Class B, Degree of Protection IP55,

Method of Cooling: Totally Enclosed Fan Cooled, Duty S1, Ambient Temperature 50°C, Conforms to IS/IEC 60034 & IS: 12615.

3000 rpm 2 Pole: Cast Iron Construction				
KW	HP	Frame	Type Reference	LP39
1.50	2.00	90S	2H09S243CT000	19,620
2.20	3.00	90L	2H09L273CT000	23,940
3.70	5.00	100L	2H10L233CT000	30,520
5.50	7.50	132S	2H13S2G3CT000	52,630
7.50	10.00	132S	2H13S2N3CT000	58,110
9.30	12.50	160M	2H16M233CT000	91,890
11.00	15.00	160M	2H16M253CT000	98,610
15.00	20.00	160M	2H16M263CT000	1,09,020
18.50	25.00	160L	2H16L293CT000	1,36,790
22.00	30.00	180M	2H18M233CT000	1,54,220
30.00	40.00	200L	2H20L2A3CT000	2,31,900
37.00	50.00	200L	2H20L273CT000	2,73,590
45.00	60.00	225M	2H22M253CT000	3,52,060
55.00	75.00	250M	2H25M23300000	4,73,550
75.00	100.00	280S	2H28S23300000	5,91,080
90.00	120.00	280M	2H28M25300000	6,74,960
110.00	150.00	315S	2H31S23300000	8,94,590
125.00	170.00	315M	2H31M2A300000	10,29,640
132.00	180.00	315M	2H31M23300000	10,78,580
150.00	200.00	315L	2H31L2A300000	11,62,860
160.00	215.00	315L	2H31L25300000	11,83,650
180.00	240.00	315L	2H31L2B300000	12,44,910
200.00	270.00	355L	2H35L2A300000	14,49,560
250.00	335.00	355L	2H35L21300000	15,70,580
315.00	425.00	355L	2H35L23300000	17,10,910

1500 rpm 4 Pole: Cast Iron Construction				
KW	HP	Frame	Type Reference	LP39
1.10	1.50	90S	2H09S423CT000	19,400
1.50	2.00	90L	2H09L473CT000	23,320
2.20	3.00	100L	2H10L473CT000	28,060
3.70	5.00	112M	2H11M473CT000	35,570
5.50	7.50	132S	2H13S4K3CT000	50,600
7.50	10.00	132M	2H13M4T3CT000	57,460
9.30	12.50	160M	2H16M4C3CT000	92,670
11.00	15.00	160M	2H16M4K3CT000	94,190
15.00	20.00	160L	2H16L4T3CT000	1,15,420
18.50	25.00	180M	2H18M473CT000	1,56,050
22.00	30.00	180L	2H18L483CT000	1,67,590
30.00	40.00	200L	2H20L45300000	2,23,400
37.00	50.00	225S	2H22S43300000	2,87,150
45.00	60.00	225M	2H22M45300000	3,24,380
55.00	75.00	250M	2H25M43300000	4,37,290
75.00	100.00	280S	2H28S42300000	5,44,570
90.00	120.00	280M	2H28M45300000	6,19,930
110.00	150.00	315S	2H31S41300000	7,71,430
125.00	170.00	315M	2H31M4A300000	8,83,830
132.00	180.00	315M	2H31M43300000	9,08,980
150.00	200.00	315L	2H31L4A300000	10,15,540
160.00	215.00	315L	2H31L45300000	10,61,140
180.00	240.00	315L	2H31L46300000	11,22,690
200.00	270.00	315L	2H31L47300000	12,81,190
250.00	335.00	355L	2H35L41300000	15,50,010
315.00	425.00	355L	2H35L43300000	18,12,000
355.00	475.00	355L	2H35L45300000	22,03,930

3000 rpm 2 Pole: Aluminium Construction				
KW	HP	Frame	Type Reference	LP39
0.37	0.50	71	2H0712A300000	11,610
0.55	0.75	71	2H07123300000	14,300
0.75	1.00	80	2H080213AT000	14,770
1.10	1.50	80	2H080233AT000	16,190
1.50	2.00	90S	2H09S243AT000	18,690
2.20	3.00	90L	2H09L273AT000	23,940
3.70	5.00	100L	2H10L233AT000	29,630
5.50	7.50	132S	2H13S2G3AT000	49,190
7.50	10.00	132S	2H13S2N3AT000	54,410

1500 rpm 4 Pole: Aluminium Construction				
KW	HP	Frame	Type Reference	LP39
0.37	0.50	71	2H07143300000	11,680
0.55	0.75	80	2H080433AT000	14,740
0.75	1.00	80	2H080453AT000	15,250
1.10	1.50	90S	2H09S423AT000	18,480
1.50	2.00	90L	2H09L473AT000	22,640
2.20	3.00	100L	2H10L473AT000	26,720
3.70	5.00	112M	2H11M473AT000	33,880
5.50	7.50	132S	2H13S4K3AT000	47,290
7.50	10.00	132M	2H13M4T3AT000	55,790

Frames 71 to 132 are with Aluminium body with Terminal Box position as Top only.

Frames 90 to 132 can be offered in Cast Iron construction with Terminal Box on Top as standard. TB on LHS or RHS can be offered on request.

Frames 160 and above are in Cast Iron construction with TB on TOP as standard. TB on LHS or RHS can be offered on request.

* GST extra as applicable at the time of delivery.

IE2 SERIES SAFE AREA MOTORS

Foot mounted (B3 construction) 3 Phase Squirrel Cage Induction Motors suitable for 415V $\pm 10\%$, 50Hz $\pm 5\%$,

Combined Variation $\pm 10\%$, Insulation Class F, with temperature rise limited to Class B, Degree of Protection IP55,

Method of Cooling: Totally Enclosed Fan Cooled, Duty S1, Ambient Temperature 50°C, Conforms to IS/IEC 60034 & IS: 12615.

1000 rpm 6 Pole: Cast Iron Construction				
kW	HP	Frame	Type Reference	LP39
0.75	1.00	90S	2H09S633CT000	18,980
1.10	1.50	90L	2H09L653CT000	21,250
1.50	2.00	100L	2H10L633CT000	29,360
2.20	3.00	112M	2H11M653CT000	34,250
3.70	5.00	132S	2H13S6G3CT000	49,540
5.50	7.50	132M	2H13M6T3CT000	60,750
7.50	10.00	160M	2H16M633CT000	91,960
9.30	12.50	160L	2H16L663CT000	1,00,840
11.00	15.00	160L	2H16L673CT000	1,12,350
15.00	20.00	180L	2H18L633CT000	1,52,610
18.50	25.00	200L	2H20L633CT000	2,10,090
22.00	30.00	200L	2H20L653CT000	2,25,940
30.00	40.00	225M	2H22M643CT000	3,25,760
37.00	50.00	250M	2H25M63300000	4,38,030
45.00	60.00	280S	2H28S61300000	5,27,320
55.00	75.00	280M	2H28M63300000	6,00,890
75.00	100.00	315S	2H31S61300000	7,32,810
90.00	120.00	315M	2H31M63300000	9,21,590
110.00	150.00	315M	2H31M65300000	10,23,110
125.00	170.00	315L	2H31L6A300000	11,30,530
132.00	180.00	315L	2H31L67300000	12,04,680
150.00	200.00	315L	2H31L6B300000	12,06,720
160.00	215.00	315L	2H31L69300000	12,36,520
180.00	240.00	355L	2H35L6A300000	14,08,670
200.00	270.00	355L	2H35L61300000	15,05,040
250.00	335.00	355L	2H35L63300000	16,53,050

750 rpm, 8 pole, Cast Iron Construction				
kW	HP	Frame	Type Reference	LP39
0.37	0.5	90S	2H09S813CT000	19,180
0.55	0.75	90L	2H09L853CT000	20,990
0.75	1	100L	2H10L813CT000	22,950
1.1	1.5	112M	2H10L833CT000	25,490
1.5	2	112M	2H11M813CT000	30,840
2.2	3	132S	2H13S8B3CT000	46,390
3.7	5	160M	2H16M813CT000	75,110
5.5	7.5	160M	2H16M833CT000	93,820
7.5	10	160L	2H16L863CT000	118,990
9.3	12.5	180M	2H18M833CR000	1,70,070
11	15	180L	2H18L873CR000	1,79,350
15	20	200L	2H20L843CR000	2,48,010
18.5	25	225S	2H22S823CR000	3,24,070
22	30	225M	2H22M833CR000	3,89,580
30	40	250M	2H25M813CT000	5,26,040
37	50	280S	2H28S823CT000	6,85,980
45	60	280M	2H28M853CT000	7,92,630

750 rpm, 8 pole, Aluminium Construction				
kW	HP	Frame	Type Reference	LP39
0.37	0.5	90S	2H09S813AT000	19,180
0.55	0.75	90L	2H09L853AT000	20,990
0.75	1	100L	2H10L813AT000	22,950
1.1	1.5	100L	2H10L833AT000	25,490
1.5	2	112M	2H11M813AT000	30,840
2.2	3	132S	2H13S8B3AT000	46,390

1000 rpm 6 Pole: Aluminium Construction				
kW	HP	Frame	Type Reference	LP39
0.37	0.50	80	2H080613CT000	15,930
0.55	0.75	80	2H080633CT000	16,390
0.75	1.00	90S	2H09S633AT000	18,430
1.10	1.50	90L	2H09L653AT000	20,240
1.50	2.00	100L	2H10L633AT000	28,500
2.20	3.00	112M	2H11M653AT000	32,700
3.70	5.00	132S	2H13S6G3AT000	48,100
5.50	7.50	132M	2H13M6T3AT000	60,750



Frames 71 to 132 are with Aluminium body with Terminal Box position as Top only.

Frames 90 to 132 can be offered in Cast Iron construction with Terminal Box on Top as standard. TB on LHS or RHS can be offered on request.

Frames 160 and above are in Cast Iron construction with TB on TOP as standard. TB on LHS or RHS can be offered on request.

* GST extra as applicable at the time of delivery.

IE3 SERIES SAFE AREA MOTORS

Foot mounted (B3 construction) 3 Phase Squirrel Cage Induction Motors suitable for 415V $\pm 10\%$, 50Hz $\pm 5\%$, Combined Variation $\pm 10\%$, Insulation Class F with temperature rise limited to Class B, Degree of Protection IP55, Ambient Temperature 50°C, Duty S1, Method of Cooling: Totally Enclosed Fan Cooled, Conforms to IS/IEC 60034 & IS: 12615

3000 rpm, 2 Pole: Cast Iron Construction				
kW	HP	Frame	Type Reference	LP39
0.75	1.00	80	3H0802B3CT000	19,220
1.10	1.50	80	3H0802E3CT000	21,980
1.50	2.00	90S	3H09S2B3CT000	22,890
2.20	3.00	90L	3H09L2E3CT000	27,140
3.70	5.00	100L	3H10L2B3CT000	35,470
5.50	7.50	132S	3H13S2C3CT000	59,400
7.50	10.00	132S	3H13S2H3CT000	63,470
9.30	12.50	160M	3H16M2B3CT000	1,19,610
11.00	15.00	160M	3H16M2E3CT000	1,25,880
15.00	20.00	160M	3H16M2H3CT000	1,33,240
18.50	25.00	160L	3H16L2M3CT000	1,57,200
22.00	30.00	180M	3H18M2B3CT000	1,87,010
30.00	40.00	200L	3H20L2B3CT000	2,65,530
37.00	50.00	200L	3H20L2E3CT000	3,08,550
45.00	60.00	225M	3H22M2B3CT000	3,87,010
55.00	75.00	250M	3H25M2E3CT000	5,23,150
75.00	100.00	280S	3H28S2E3CT000	6,54,500
90.00	120.00	280M	3H28M2H3CT000	7,53,280
110.00	150.00	315S	3H31S2E3CT000	9,51,210
132.00	180.00	315L	3H31L2H3CT000	Refer Sales Office
150.00	200.00	315L	3H31L2K3CT000	Refer Sales Office
160.00	215.00	315L	3H31L2M3CT000	Refer Sales Office
180.00	240.00	355L	3H35L2A3CT000	14,60,970
200.00	270.00	355L	3H35L2B3CT000	15,29,550
225.00	335.00	355L	3H35L2C3CT000	16,38,730
250.00	335.00	355L	3H35L2E3CT000	17,22,160
280.00	375.00	355L	3H35L2G3CT000	18,48,000

1500 rpm, 4 Pole: Cast Iron Construction				
kW	HP	Frame	Type Reference	LP39
0.55	0.75	80	3H0804B3CT000	17,800
0.75	1.00	80	3H0804E3CT000	20,820
1.10	1.50	90S	3H09S4B3CT000	22,240
1.50	2.00	90L	3H09L4E3CT000	26,100
2.20	3.00	100L	3H10L4B3CT000	32,090
3.70	5.00	112M	3H11M4B3CT000	40,200
5.50	7.50	132S	3H13S4C3CT000	57,120
7.50	10.00	132M	3H13M4H3CT000	66,500
9.30	12.50	160M	3H16M4E3CT000	1,11,340
11.00	15.00	160M	3H16M4H3CT000	1,15,000
15.00	20.00	160L	3H16L4M3CT000	1,34,000
18.50	25.00	180M	3H18M4B3CT000	1,83,210
22.00	30.00	180L	3H18L4E3CT000	1,97,660
30.00	40.00	200L	3H20L4B3CT000	2,52,890
37.00	50.00	225S	3H22S4B3CT000	3,26,850
45.00	60.00	225M	3H22M4E3CT000	3,72,080
55.00	75.00	250M	3H25M4B3CT000	4,94,340
75.00	100.00	280S	3H28S4B3CT000x	6,00,490
90.00	120.00	280M	3H28M4H3CT000x	7,01,890
110.00	150.00	315S	3H31S4G3CT000	8,36,000
132.00	180.00	315M	3H31M4K3CT000	9,92,750
160.00	215.00	315L	3H31L4P3CT000	12,54,750
200.00	270.00	315L	3H31L4W3CT000	14,02,500
225.00	300.00	355L	3H35L4B3CT000	17,19,890
250.00	335.00	355L	3H35L4E3CT000	17,75,640
315.00	422.00	355L	3H35L4H3CT000	20,06,830

3000 rpm, 2 Pole: Aluminium Construction				
kW	HP	Frame	Type Reference	LP39
1.50	2.00	90S	3H09S2B3AT000	22,220
2.20	3.00	90L	3H09L2E3AT000	26,600
3.70	5.00	100L	3H10L2B3AT000	35,470
5.50	7.50	132S	3H13S2C3AT000	54,000
7.50	10.00	132S	3H13S2H3AT000	57,700

1500 rpm 4 Pole: Aluminium Construction				
kW	HP	Frame	Type Reference	LP39
1.10	1.50	90S	3H09S4B3AT000	21,180
1.50	2.00	90L	3H09L4E3AT000	24,930
2.20	3.00	100L	3H10L4B3AT000	31,480
3.70	5.00	112M	3H11M4B3AT000	39,030
5.50	7.50	132S	3H13S4C3AT000	54,400
7.50	10.00	132M	3H13M4H3AT000	63,940

Cast Iron construction Motors are with Top TB as standard feature, can be offered with RHS, LHS T Box on request
 Aluminum construction motors are offered with Top TB only.
 Motors are with Inverter grade winding with 6 leads.

*GST extra as applicable at the time of delivery.

IE3 SERIES SAFE AREA MOTORS

Foot mounted (B3 construction) 3 Phase Squirrel Cage Induction Motors suitable for 415V $\pm 10\%$, 50Hz $\pm 5\%$, Combined Variation $\pm 10\%$, Insulation Class F with temperature rise limited to Class B, Degree of Protection IP55, Ambient Temperature 50°C, Duty S1, Method of Cooling: Totally Enclosed Fan Cooled, Conforms to IS/IEC 60034 & IS: 12615

1000 rpm, 6 Pole: Cast Iron Construction				
kW	HP	Frame	Type Reference	LP39
0.37	0.50	80	3H0806B3CT000	18,640
0.55	0.75	80	3H0806E3CT000	20,000
0.75	1.00	90S	3H09S6B3CT000	24,580
1.10	1.50	90L	3H09L6E3CT000	28,050
1.50	2.00	100L	3H10L6B3CT000	35,840
2.20	3.00	112M	3H11M6B3CT000	39,390
3.70	5.00	132S	3H13S6C3CT000	59,130
5.50	7.50	132M	3H13M6H3CT000	69,730
7.50	10.00	160M	3H16M6B3CT000	1,08,240
9.30	12.50	160L	3H16L6E3CT000	1,20,730
11.00	15.00	160L	3H16L6H3CT000	1,29,110
15.00	20.00	180L	3H18L6B3CT000	1,80,290
18.50	25.00	200L	3H20L6B3CT000	2,36,490
22.00	30.00	200L	3H20L6E3CT000	2,60,880
30.00	40.00	225M	3H22M6B3CT000	3,62,570
37.00	50.00	250M	3H25M6B3CT000	4,87,760
45.00	60.00	280S	3H28S6B3CT000	5,92,900
55.00	75.00	280M	3H28M6E3CT000	6,81,520
75.00	100.00	315S	3H31S6B3CT000	8,06,190
90.00	120.00	315M	3H31M6E3CT000	10,01,000
110.00	150.00	315M	3H31M6H3CT000	11,55,000
132.00	180.00	315L	3H31L6M3CT000	13,15,490
160.00	215.00	355L	3H35L6B3CT000	13,80,500
180.00	240.00	355L	3H35L6C3CT000	15,91,870
200.00	270.00	355L	3H35L6E3CT000	17,55,930
250.00	335.00	355L	3H35L6H3CT000	19,31,770

750 rpm, 8 pole, Cast Iron Construction				
kW	HP	Frame	Type Reference	LP39
0.37	0.5	90S	3H09S853CT000	22,090
0.55	0.75	90L	3H09L863CT000	24,160
0.75	1	100L	3H10L833CT000	26,340
1.10	1.5	100L	3H10L853CT000	28,890
1.50	2	112M	3H11M833CT000	36,670
2.20	3	132S	3H13S8G3CT000	54,740
3.70	5	160M	3H16M823CT000	86,380
5.50	7.5	160M	3H16M843CT000	1,07,050
7.50	10	160L	3H16L883CT000	1,36,860
9.30	12.5	180M	3H18M873CT000	1,95,600
11.00	15	180L	3H18L893CT000	2,06,280
15.00	20	200L	3H20L853CT000	2,52,530
18.50	25	225S	3H22S823CT000	3,72,680
22.00	30	225M	3H22M833CT000	4,48,040
30.00	40	250M	3H25M813CT000	6,04,960
37.00	50	280S	3H28S823CT000	7,88,910
45.00	60	280M	3H28M853CT000	9,11,530

750 rpm, 8 pole, Aluminium Construction				
kW	HP	Frame	Type Reference	LP39
0.37	0.5	90S	3H09S853AT000	22,090
0.55	0.75	90L	3H09L863AT000	24,160
0.75	1	100L	3H10L833AT000	26,340
1.10	1.5	100L	3H10L853AT000	28,890
1.50	2	112M	3H11M833AT000	36,670
2.20	3	132S	3H13S8G3AT000	54,740

1000 rpm, 6 Pole: Aluminium Construction				
kW	HP	Frame	Type Reference	LP39
0.75	1.00	90S	3H09S6B3AT000	21,370
1.10	1.50	90L	3H09L6E3AT000	28,050
1.50	2.00	100L	3H10L6B3AT000	35,840
2.20	3.00	112M	3H11M6B3AT000	38,640
3.70	5.00	132S	3H13S6C3AT000	56,310
5.50	7.50	132M	3H13M6H3AT000	69,730



Cast Iron construction Motors are with Top TB as standard feature, can be offered with RHS, LHS T Box on request
 Aluminum construction motors are offered with Top TB only.
 Motors are with Inverter grade winding with 6 leads.

*GST extra as applicable at the time of delivery.

FLP MOTORS: STANDARD RANGE

Foot mounted (B3 construction) 3 Phase Squirrel Cage Induction Motor, 415V $\pm 10\%$, 50Hz $\pm 5\%$, Combined Variation $\pm 10\%$,
 Insulation Class F, with temperature rise limited to Class B, Degree of Protection IP55, Duty S1, Ambient Temperature 45°C,
 Method of Cooling: Totally Enclosed Fan Cooled, Conforms to IS/IEC 60034-1, IS/IEC 60079-1:2007, Gas Group IIA, IIB.

3000 rpm, 2 Pole				
kW	HP	Frame	Type Reference	LP39
0.37	0.50	80	MD0802A300000	27,490
0.55	0.75	80	MD0802B300000	30,460
0.75	1.00	80	MD08021300000	31,400
1.1	1.50	80	MD08023300000	34,940
1.5	2.00	90 L	MD09L23300000	37,050
2.2	3.00	90 L	MD09L25300000	49,000
3.7	5.00	100 L	MD10L21300000	62,210
5.5	7.50	132M	MD13S2B300000	88,700
7.5	10.00	132M	MD13S2E300000	97,180
9.3	12.50	132M	MD13M2N300000	1,51,230
11	15.00	160M	MD16M21300000	1,78,330
15	20.00	160M	MD16M25300000	2,08,230
18.5	25.00	160L	MD16L27300000	2,36,350
22	30.00	180L	MD18L21300000	2,79,660
30	40.00	200L	MD20L23300000	3,76,890
37	50.00	200L	MD20L25300000	4,88,230
45	60.00	225M	MD22M23300000	6,16,730
55	75.00	250M	MD25M21300000	7,49,360
75	100.00	280S	MD28S21300000	9,46,240
90	120.00	280M	MD28M23300000	10,19,460

1500 rpm, 4 Pole				
kW	HP	Frame	Type Reference	LP39
0.37	0.50	80	MD0804A300000	26,970
0.55	0.75	80	MD08041300000	29,510
0.75	1.00	80	MD08043300000	30,730
1.1	1.50	90 L	MD09L43300000	35,030
1.5	2.00	90 L	MD09L45300000	38,130
2.2	3.00	100 L	MD10L43300000	48,430
3.7	5.00	112M	MD11M43300000	60,750
5.5	7.50	132M	MD13S4B300000	83,800
7.5	10.00	132M	MD13M4K300000	95,340
9.3	12.50	160M	MD16M4A300000	1,51,470
11	15.00	160M	MD16M4C300000	1,54,550
15	20.00	160L	MD16L4K300000	1,89,620
18.5	25.00	180L	MD18L43300000	2,12,310
22	30.00	180L	MD18L47300000	2,52,220
30	40.00	200L	MD20L43300000	3,39,810
37	50.00	225S	MD22S41300000	4,41,520
45	60.00	225M	MD22M43300000	5,55,480
55	75.00	250M	MD25M41300000	6,81,540
75	100.00	280S	MD28S41300000	8,59,540
90	120.00	280M	MD28M43300000	8,76,080

1000 rpm, 6 Pole				
kW	HP	Frame	Type Reference	LP39
0.37	0.50	80	MD08061300000	30,890
0.55	0.75	80	MD08063300000	31,990
0.75	1.00	90L	MD09L63300000	37,220
1.10	1.50	90L	MD09L65300000	38,260
1.50	2.00	100L	MD10L63300000	54,800
2.20	3.00	112M	MD11M63300000	63,840
3.70	5.00	132M	MD13S6B300000	84,550
5.50	7.50	132M	MD13M6N300000	1,02,570
7.50	10.00	160M	MD16M63300000	1,61,850
9.30	12.50	160L	MD16L66300000	1,79,780
11.00	15.00	160L	MD16L67300000	1,97,580
15.00	20.00	180L	MD18L61300000	2,59,710
18.50	25.00	200L	MD20L61300000	3,21,740
22.00	30.00	200L	MD20L63300000	3,48,870
30.00	40.00	225M	MD22M62300000	5,71,710
37.00	50.00	250M	MD25M60300000	7,03,700
45.00	60.00	280S	MD28S61300000	8,37,050
55.00	75.00	280M	MD28M63300000	9,02,260

750 rpm, 8 Pole				
kW	HP	Frame	Type Reference	LP39
0.37	0.50	90L	MD09L83300000	36,620
0.55	0.75	90L	MD09L85300000	39,590
0.75	1.00	100L	MD10L81300000	48,680
1.10	1.50	100L	MD10L83300000	56,640
1.50	2.00	112M	MD11M81300000	67,710
2.20	3.00	132M	MD13S8B300000	89,200
3.70	5.00	160M	MD16M81300000	1,44,050
5.50	7.50	160M	MD16M83300000	1,68,660
7.50	10.00	160L	MD16L87300000	2,05,430
9.30	12.50	180L	MD18L81300000	2,60,620
11.00	15.00	180L	MD18L83300000	2,74,680
15.00	20.00	200L	MD20L83300000	3,70,760
18.50	25.00	225S	MD22S81300000	4,60,210
22.00	30.00	225M	MD22M83300000	6,04,930
30.00	40.00	250M	MD25M81300000	7,42,950
37.00	50.00	280S	MD28S82300000	9,53,320
45.00	60.00	280M	MD28M85300000	9,73,520

All motors are with T Box on top.

Frames 112 & 132 can be offered with T Box on RHS on request.

Frames 160 to 280 can be offered with T Box on RHS/LHS on request.

For higher ratings refer to IE2 Series Motors.

*GST extra as applicable at the time of delivery.

FLP MOTORS: Efficiency Values Complying to IE2 Class

Foot mounted (B3 construction) 3 Phase Squirrel Cage Induction Motor, 415V $\pm 10\%$, 50Hz $\pm 5\%$, , Combined Variation $\pm 10\%$,

Insulation Class F, with temperature rise limited to Class B, Degree of Protection IP55, Duty S1, Ambient Temp 45°C,

Method of Cooling: Totally Enclosed Fan Cooled, Conforms to IS/IEC:60034-1, IS/IEC 60079-1:2007, IE2 Efficiency Class, Gas Group IIA, IIB.

3000 rpm 2 Pole				
kW	HP	Frame	Type Reference	LP39
0.37	0.50	80	2J0802A300000	31,630
0.55	0.75	80	2J0802B300000	35,350
0.75	1.00	80	2J08021300000	36,430
1.10	1.50	80	2J08023300000	40,810
1.50	2.00	90L	2J09L24300000	42,640
2.20	3.00	90L	2J09L27300000	57,310
3.70	5.00	100L	2J10L23300000	72,830
5.50	7.50	132S	2J13S2G300000	1,02,770
7.50	10.00	132S	2J13S2N300000	1,13,380
9.30	12.50	160M	2J16M23300000	1,92,660
11.00	15.00	160M	2J16M25300000	1,93,690
15.00	20.00	160M	2J16M26300000	2,32,520
18.50	25.00	160L	2J16L29300000	2,64,520
22.00	30.00	180L	2J18L23300000	3,10,890
30.00	40.00	200L	2J20L2A300000	4,23,650
37.00	50.00	200L	2J20L25300000	5,49,680
45.00	60.00	225M	2J22M25300000	6,94,640
55.00	75.00	250M	2J25M23300000	8,55,820
75.00	100.00	280M	2J28M23300000	10,50,270
90.00	120.00	280M	2J28M25300000	11,30,530
110.00	150.00	315S	2J31S23300000	13,46,550
125.00	170.00	315M	2J31M2A300000	15,37,310
132.00	180.00	315M	2J31M23300000	15,53,030
150.00	200.00	315L	2J31L2A300000	17,06,430
160.00	215.00	315L	2J31L25300000	17,60,740
180.00	240.00	315L	2J31L2B300000	21,11,010

1500 rpm 4 Pole				
kW	HP	Frame	Type Reference	LP39
0.37	0.50	80	2J08041300000	31,070
0.55	0.75	80	2J08043300000	34,290
0.75	1.00	80	2J08045300000	35,650
1.10	1.50	90L	2J09L42300000	40,790
1.50	2.00	90L	2J09L47300000	44,500
2.20	3.00	100L	2J10L47300000	58,730
3.70	5.00	112M	2J11M47300000	71,710
5.50	7.50	132S	2J13S4K300000	98,080
7.50	10.00	132M	2J13M4T300000	1,12,340
9.30	12.50	160M	2J16M4C300000	1,64,670
11.00	15.00	160M	2J16M4K300000	1,74,000
15.00	20.00	160L	2J16L4T300000	2,11,920
18.50	25.00	180L	2J18L47300000	2,47,360
22.00	30.00	180L	2J18L48300000	2,83,730
30.00	40.00	200L	2J20L45300000	3,85,460
37.00	50.00	225M	2J22M43300000	5,02,040
45.00	60.00	225M	2J22M45300000	6,35,940
55.00	75.00	250M	2J25M43300000	7,79,160
75.00	100.00	280S	2J28S42300000	9,52,650
90.00	120.00	280M	2J28M45300000	9,71,090
110.00	150.00	315S	2J31S41300000	11,60,760
125.00	170.00	315M	2J31M4A300000	13,35,980
132.00	180.00	315M	2J31M43300000	14,04,620
150.00	200.00	315L	2J31L4A300000	14,46,590
160.00	215.00	315L	2J31L45300000	14,74,900
180.00	240.00	315L	2J31L46300000	17,65,520
#200	270.00	315L	2J31L47300000	21,05,780

All motors are with T Box on top as standard feature.

Frames 112 & 132 can be offered with T Box on RHS on request.

Frames 160 to 280 can be offered with T Box on RHS/LHS on request.

This rating is suitable for Ambient Temperature 40° C.

*GST extra as applicable at the time of delivery.

FLP MOTORS: Efficiency Values Complying to IE2 Class

Foot mounted (B3 construction) 3 Phase Squirrel Cage Induction Motor, 415V $\pm 10\%$, 50Hz $\pm 5\%$, Combined Variation $\pm 10\%$, Insulation Class F, with temperature rise limited to Class B, Degree of Protection IP55, Duty S1, Ambient Temperature 45°C, Method of Cooling: Totally Enclosed Fan Cooled, Conforms to IS/IEC:60034-1, IS/IEC 60079-1:2007, IE2 Efficiency Class, Gas Group IIA, IIB.

1000 rpm 6 Pole				
kW	HP	Frame	Type Reference	LP39
0.37	0.50	80	2J08061300000	36,120
0.55	0.75	80	2J08063300000	37,060
0.75	1.00	90L	2J09L633000000	43,200
1.10	1.50	90L	2J09L653000000	44,460
1.50	2.00	100L	2J10L633000000	64,380
2.20	3.00	112M	2J11M653000000	74,830
3.70	5.00	132S	2J13S6G3000000	99,130
5.50	7.50	132M	2J13M6T3000000	1,20,150
7.50	10.00	160M	2J16M633000000	1,85,900
9.30	12.50	160L	2J16L663000000	2,14,850
11.00	15.00	160L	2J16L673000000	2,27,700
15.00	20.00	180L	2J18L633000000	2,91,280
18.50	25.00	200L	2J20L633000000	3,65,670
22.00	30.00	200L	2J20L653000000	3,96,660
30.00	40.00	225M	2J22M643000000	6,50,270
37.00	50.00	250M	2J25M633000000	7,98,650
45.00	60.00	280S	2J28S613000000	9,27,550
55.00	75.00	280M	2J28M633000000	10,00,460
75.00	100.00	315S	2J31S613000000	11,73,170
90.00	120.00	315M	2J31M633000000	13,75,710
110.00	150.00	315M	2J31M653000000	15,08,250
125.00	170.00	315L	2J31L6A3000000	17,84,690
132.00	180.00	315L	2J31L673000000	18,28,240
150.00	200.00	315L	2J31L6B3000000	21,39,370
160.00	215.00	315L	2J31L693000000	23,03,440

750 rpm, 8 pole				
kW	HP	Frame	Type Reference	LP39
0.37	0.5	90L	2J09L833000000	39,430
0.55	0.75	90L	2J09L853000000	42,680
0.75	1	100L	2J10L813000000	51,630
1.10	1.5	100L	2J10L833000000	60,100
1.50	2	112M	2J11M813000000	72,080
2.20	3	132S	2J13S8B3000000	95,250
3.70	5	160M	2J16M813000000	1,54,130
5.50	7.5	160M	2J16M833000000	1,67,510
7.50	10	160L	2J16L863000000	2,15,810
9.30	12.5	180L	2J18L833000000	3,40,150
15.00	20	200L	2J20L843000000	4,84,340
18.50	25	225S	2J22S823000000	6,01,290
22.00	30	225M	2J22M833000000	7,91,370
30.00	40	250M	2J25M813000000	9,71,930
37.00	50	280S	2J28S823000000	12,47,250
45.00	60	280M	2J28M853000000	13,40,480



All motors are with T Box on top as standard feature.
 Frames 112 & 132 can be offered with T Box on RHS on request.
 Frames 160 to 280 can be offered with T Box on RHS/LHS on request.

*GST extra as applicable at the time of delivery.

FLP MOTORS: Efficiency Values Complying to IE3 Class

Foot mounted (B3 construction) 3 Phase Squirrel Cage Induction Motor, 415V $\pm 10\%$, 50Hz $\pm 5\%$, , Combined Variation $\pm 10\%$,

Insulation Class F, with temperature rise limited to Class B, Degree of Protection IP55, Duty S1, Ambient Temp: 45°C,

Method of Cooling: Totally Enclosed Fan Cooled, Conforms to IS/IEC:60034-1, IS/IEC 60079-1:2007, IE3 Efficiency Class, Gas Group IIA, IIB.

3000 rpm, 2 pole				
kW	HP	Frame	Type Reference	LP39
1.5	2	90L	3J09L2B300000	50,710
2.2	3	90L	3J09L2E300000	65,330
3.7	5	100L	3J10L2B300000	83,030
5.5	7.5	132S	3J13S2C300000	1,17,160
7.5	10	132S	3J13S2H300000	1,29,250
9.3	12.5	160M	3J16M2B300000	2,19,630
11	15	160M	3J16M2E300000	2,20,810
15	20	160M	3J16M2H300000	2,61,820
18.5	25	160L	3J16L2M300000	3,01,550
22	30	20L	3J20L2S300000	3,50,780
30	40	22M	3J22M2S300000	4,76,370
37	50	22M	3J22M2S300000	5,95,290
45	60	25M	3J25M2S300000	7,09,300
55	75	28S	3J28S2A300000	9,67,430
75	100	28S	3J28S2E300000	11,31,830
90	120	28M	3J28M2H300000	12,66,560

1500 rpm, 4 pole				
kW	HP	Frame	Type Reference	LP39
1.1	1.5	90L	3J09L4B300000	47,590
1.5	2	90L	3J09L4E300000	52,250
2.2	3	100L	3J10L4B300000	70,300
3.7	5	112M	3J11M4B300000	81,750
5.5	7.5	132S	3J13S4C300000	1,11,810
7.5	10	132M	3J13M4H300000	1,28,070
9.3	12.5	160M	3J16M4E300000	1,91,020
11	15	160M	3J16M4H300000	1,98,360
15	20	160L	3J16L4M300000	2,41,570
18.5	25	20L	3J20L4A300000	2,87,200
22	30	20L	3J20L4S300000	3,19,840
30	40	22M	3J22M4S300000	4,36,460
37	50	25M	3J25M4A300000	5,80,190
45	60	25M	3J25M4S300000	6,79,180
55	75	28S	3J28S4S300000	8,45,760
75	100	28S	3J28S4B300000	10,11,700
90	120	28M	3J28M4H300000	10,70,010

All motors are with T Box on top.

Frames 112 & 132 can be offered with T Box on RHS on request.

Frames 160 to 280 can be offered with T Box on RHS/LHS on request.

*GST extra as applicable at the time of delivery.

FLP MOTORS : Efficiency Values Complying to IE3 Class

Foot mounted (B3 construction) 3 Phase Squirrel Cage Induction Motor, 415V $\pm 10\%$, 50Hz $\pm 5\%$, Combined Variation $\pm 10\%$, Insulation Class F, with temperature rise limited to Class B, Degree of Protection IP55, Duty S1, Ambient Temperature 45°C, Method of Cooling: Totally Enclosed Fan Cooled, Conforms to IS/IEC:60034-1, IS/IEC 60079-1:2007, IE3 Efficiency Class, Gas Group IIA, IIB.

1000 rpm, 6 pole				
kW	HP	Frame	Type Reference	LP39
0.75	1	90L	3J09L6B300000	49,250
1.1	1.5	90L	3J09L6E300000	53,210
1.5	2	100L	3J10L6B300000	72,140
2.2	3	112M	3J11M6B300000	85,310
3.7	5	132S	3J13S6C300000	1,13,010
5.5	7.5	132M	3J13M6H300000	1,36,970
7.5	10	160M	3J16M6B300000	2,03,740
9.3	12.5	160L	3J16L6E300000	2,11,510
11	15	160L	3J16L6H300000	2,66,410
15	20	20L	3J20L63300000	3,29,630
18.5	25	20L	3J20L65300000	4,10,630
22	30	22M	3J22M62300000	4,42,180
30	40	25M	3J25M60300000	7,02,280
37	50	25M	3J25M6B300000	8,92,510
45	60	28S	3J28S6B300000	10,06,470
55	75	28M	3J28M6E300000	11,06,220

750 rpm, 8 pole				
kW	HP	Frame	Type Reference	LP39
0.37	0.5	90L	3J09L85300000	60,670
0.55	0.75	90L	3J09L86300000	62,300
0.75	1	100L	3J10L83300000	79,730
1.1	1.5	100L	3J10L85300000	82,650
1.5	2	112M	3J11M83300000	93,680
2.2	3	132S	3J13S8B300000	1,24,400
3.7	5	160M	3J16M82300000	1,95,660
5.5	7.5	160M	3J16M84300000	2,32,110
7.5	10	160L	3J16L88300000	2,43,300

All motors are with T Box on top.

Frames 112 & 132 can be offered with T Box on RHS on request.

Frames 160 to 280 can be offered with T Box on RHS/LHS on request.

*GST extra as applicable at the time of delivery.

CRANE & HOIST DUTY MOTORS

Foot mounted (B3 construction) 3 Phase Squirrel Cage Induction Motors suitable to operate on DOL supply: 415V $\pm 10\%$, 50Hz $\pm 5\%$

Combined Variation $\pm 10\%$, Insulation Class F, Degree of Protection IP55, Ambient Temperature 45°C, Method of Cooling:

Totally Enclosed Fan Cooled, 150 Starts/Stops per hour, Duty S4, CDF 40% conforms to IS/IEC 60034

1500 rpm, 4 Pole				
kW	HP	Frame	Type Reference	LP39
0.55	0.75	71	MC071433	14,250
0.75	1.00	80	MC080413	15,840
1.10	1.50	80	MC080433	15,950
1.50	2.00	90S	MC09S433	17,640
2.20	3.00	90L	MC09L453	19,220
3.70	5.00	100L	MC10L453	27,640
5.50	7.50	112M	MC11M453	32,360
7.50	10.00	132S	MC13S4G3	47,580
9.30	12.50	132M	MC13M4P3	58,510
11.00	15.00	160M	MC16M4A3	82,020
15.00	20.00	160M	MC16M4F3	88,200
18.50	25.00	160L	MC16L4P3	1,03,930
22.00	30.00	180L	MC18L473	1,51,040
30.00	40.00	200L	MC20L433	2,20,860
37.00	50.00	225S	MC22S413	2,62,710
45.00	60.00	225M	MC22M433	3,25,830
55.00	75.00	250M	MC25M413	4,29,990
75.00	100.00	280S	MC28S413	5,30,000
90.00	120.00	280M	MC28M433	5,91,280
110.00	150.00	315S	MC31S413	7,96,670
132.00	160.00	315M	MC31M433	8,82,210
160.00	215.00	315L	MC31L453	10,56,370
180.00	250.00	315L	MC31L463	11,14,030
200.00	270.00	315L	MC31L473	12,47,860

1000 rpm, 6 Pole				
kW	HP	Frame	Type Reference	LP39
0.37	0.50	71	MC071633	15,890
0.55	0.75	80	MC080613	17,110
0.75	1.00	80	MC080633	17,290
1.10	1.50	90L	MC09L6A3	19,300
1.50	2.00	90L	MC09L653	21,410
2.20	3.00	100L	MC10L653	28,260
3.70	5.00	112M	MC11M653	34,630
5.50	7.50	132S	MC13S6G3	49,570
7.50	10.00	132M	MC13M6T3	58,080
9.30	12.50	160M	MC16M633	87,590
11.00	15.00	160L	MC16L663	1,03,160
13.00	17.50	160L	MC16L673	1,08,820
17.00	23.00	180L	MC18L633	1,57,430
22.00	30.00	200L	MC20L633	2,04,370
30.00	40.00	225M	MC22M623	2,84,510
37.00	50.00	250M	MC25M603	4,30,180
45.00	60.00	280S	MC28S613	5,48,120
52.00	70.00	280M	MC28M633	6,21,810
70.00	95.00	315S	MC31S613	7,63,820
85.00	115.00	315M	MC31M633	9,60,950
102.00	135.00	315M	MC31M653	10,70,450
125.00	167.00	315L	MC31L673	12,43,620
150.00	200.00	315L	MC31L693	12,94,520

750rpm, 8 Pole				
kW	HP	Frame	Type Reference	LP39
0.55	0.75	90S	MC09S813	19,900
0.75	1.00	90L	MC09L853	20,330
1.10	1.50	100L	MC10L813	23,800
1.50	2.00	100L	MC10L833	28,990
2.20	3.00	112M	MC11M833	44,510
3.70	5.00	132S	MC13S8G3	70,090
5.50	7.50	160M	MC16M833	88,200
7.50	10.00	160L	MC16L873	1,17,410
9.30	12.50	180M	MC18M813	1,40,460
11.00	15.00	180L	MC18L833	1,57,830
15.00	20.00	200L	MC20L833	2,22,350
18.50	25.00	225S	MC22S813	2,69,690
22.00	30.00	225M	MC22M833	3,25,530
30.00	40.00	250M	MC25M813	4,37,750
37.00	50.00	280S	MC28S823	5,59,480
45.00	60.00	280M	MC28M853	6,49,080
55.00	75.00	315S	MC31S813	7,76,970
75.00	100.00	315M	MC31M833	9,77,540
90.00	120.00	315M	MC31M853	10,98,290
110.00	150.00	315L	MC31L873	11,59,720
132.00	180.00	315L	MC31L893	13,58,220



Frames 71-132 are with Aluminium body with T Box on Top.

Frame 160 is with Cast Iron Body with T Box on Top.

Frames 180 -225 are with Cast Iron body with T Box on RHS.
(TOP/LHS T Box can be offered on request)

Frames 250 and above are with Cast Iron body with T Box on top.
(RHS / LHS T Box can be offered on request)

Frames 90-132 can also be offered with Cast Iron body with T Box on Top, RHS or LHS can be offered on request.

CRANE DUTY SLIP RING MOTORS

B3 construction, 3 Phase Slipring Induction Motor, 415V \pm 10%, 50Hz \pm 5% Combined Variation \pm 10%,
 Insulation for Stator/Rotor: class F/F, Degree of Protection IP55, Ambient Temperature 45°C, Method of Cooling:
 Totally Enclosed Fan Cooled, Duty S4, CDF 40%, 60 Starts / Stops per hour conforms to IS/IEC 60034

1000 rpm, 6 Pole				
kW	HP	Frame	Type Reference	LP39
1.10	1.50	100L	MP10L61300000	76,130
1.50	2.00	100L	MP10L62300000	80,430
2.40	3.20	112M	MP11M62300000	86,120
3.30	4.40	112M	MP11M64300000	95,990
4.00	5.30	132M	MP13M61300000	99,500
5.50	7.50	132M	MP13M66300000	1,16,100
7.00	9.40	160L	MP16L61300000	1,44,860
10.00	13.40	160L	MP16L65300000	1,88,070

Note:

1. This LP39 Rev.01 supercedes all our earlier Price Lists.
2. Prices mentioned are maximum recommended selling prices and are subject to change without notice.
3. Prices are exclusive of GST; GST will be extra as prevailing at the time of dispatch.
4. KW and HP are indicated, kW is binding and HP is approximate.
5. Product upgradation is a continuous process, hence data in this price list is subject to change without prior notice.

For latest information please contact our Sales Office.

Cash Extra Price Calculations:

- a) Wherever cash extras are in percentage please add to the list price and then apply discount.
- b) Where cash extras are in absolute values please add them to the discounted net price i.e. after applying the discount.

(No discount applicable on absolute values)

*GST extra as applicable at the time of delivery.



CASH EXTRAS FOR ADDITIONAL FEATURES

Sr. No.	FEATURES	Cash Extras / Percentage Extra
1.00	MECHANICAL FEATURES	
	Construction (Mounting Position)	
1.01	(a) B3, B6, B7, B8, V5 and V6	Nil
	(b) Standard Flange / Face mounting (B5, V1, V18, V19, B14 : B14 is till 132 frame)	
	(i) 63 to 160 Frame	3%
	(ii) 180 Frame and above	5%
	(c) Foot cum Flange / Face mounting (B35 / B34: B34 is till 132 frame)	
	(i) 63 to 160 Frame	3%
(ii) 180 Frame and above	5%	
1.02	Canopy	
(a)	Top plate cowl for V1 construction	5% Subject to max. Rs. 5,000/-
(b)	FRP Canopy For Safe Area: 90 and above For Flameproof: 160 and above (for other frames: Refer Sales office)	5% subject to max. Rs. 9,000/-
1.03	Shaft Extension / Material	
(a)	Single / double non std shaft, if dia or extn is less than or equal to standard	5%
(b)	Single / double non standard shaft extension with length restricted to 2.5 times standard	10%
(c)	Any other Diameter / Extension	Refer to Sales Office
(d)	EN19, EN24 / EN57 material, 45C8	10%
(e)	Stainless Steel Shaft material (SS304, SS316, SS410, SS416)	15%
(f)	Other material (if any)	Refer to Sales Office
1.04	Water Flingers: Rubber Material	
(i)	Frame 132 to 180	850/-
(ii)	Frame 200 & 225	1,000/-
(iii)	Frame 250	2,750/-
	Water Flinger of other than rubber material	Refer to Sales Office

CASH EXTRAS FOR ADDITIONAL FEATURES

Sr. No.	FEATURES	Cash Extras / Percentage Extra		
1.05	Painting			
	(a) Paint Type			
	(i) For Safe Area Motors: Other than Acrylic Paint	5% (subjected to max Rs. 5,000/-) (if safe area motor is required with AAP, then standard shade will be 632)		
	(ii) For Hazardous Area Motors (Ex'd', Ex 'nA'): Other than Acid Alkali Proof Paint	5% (subjected to max Rs. 5,000/-) (hazardous area motors are offered with Acid Alkali Proof paint as standard feature)		
	<i>(Epoxy gel coat on winding overhang and SS nameplate is standard feature for Hazardous Area Motors i.e. Ex'd', Ex 'nA' motors)</i>			
	(b) Paint Shade			
	(i) For Safe Area Motors: Other than RAL 5000	5% (subjected to max Rs. 7,000/-)		
	(ii) For Hazardous Area Motors (Ex'd', Ex 'nA'): Other than 632 shade	5% (subjected to max Rs. 7,000/-)		
	(c) Paint Thickness (for AAP type paint)			
	(i) For Additional paint thickness, more than 70 micron and upto 120 micron	Nil		
	(ii) For additional paint thickness, more than 121 micron and upto 170 micron	7%		
	(iii) For additional paint thickness, more than 171 micron and upto 220 micron	10%		
	(iv) For additional paint thickness, more than 221 micron and upto 270 micron	15%		
	1.06	Ingress Protection: IP		
(i) IP56 / IP65 / IP66		5%		
1.07	Non Sparking Motors (Type 'nA')	7.5% For the selected frame		
1.08	Impregnation Schemes	Fr. 63-225	Fr. 250-280	Fr. 315 and Above
	(a) Inverter Grade Winding	8%	8%	Nil
	(b) Only VPI	5%	5%	Nil
	(c) Motors for Inverter Duty: 500 to 690 V (Scheme III Insulation)	10%		
1.09	Forced Cooling (Fan with motor and Cowl)			
	(a) Frame 132, 160	25% With max of Rs. 6,500/-		
	(b) Frame 180 to 200	22% With max of Rs. 16,000/-		
	(c) Frame 225	12% With max of Rs. 26,000/-		
	(d) Frame 250	12% With max of Rs. 26,000/-		
	(e) Frame 280	12% With max of Rs. 30,000/-		
	(f) Frame 315	12% With max of Rs. 35,000/-		
	(g) Frame 355	12% With max of Rs. 42,000/-		
	(h) Frame 400	12% With max of Rs. 52,000/-		
1.10	Provision for Encoder Mounting	5% ; Minimum Rs. 3000/- ; Maximum Rs. 7,500/-		

CASH EXTRAS FOR ADDITIONAL FEATURES

Sr. No.	FEATURES	Cash Extras / Percentage Extra	
1.11	Space Heater: safe area and hazardous area motors Note: Space Heater is a Standard feature for DCCA Motors		
	(a) Frame 90 to 160...safe area	With max of Rs. 2,000/-	
	(b) Frame 180...for safe area	With max of Rs. 3,250/-	
	(c) Frame 200 to 280...for safe area	With max of Rs. 3,800/-	
	(d) Frame 315 and 355...for safe area	With max of Rs. 4,200/-	
	(e) Cash Extras for PESO Approved Space Heaters	71, 80	: Rs. 2450
		90, 100 & 112	: Rs. 3260
		132	: Rs. 3480
160 to 200		: Rs. 3870	
225 to 280		: Rs. 5330	
	315 & 355	: Rs. 7310	
1.12	Sealing Box for FLP Motors (Mandatorily to be considered for applications in Oil Mines and Coal Mines)		
	(a) Frame 90 to 132	Rs. 1,650/-	
	(b) Frame 160 and above	Rs. 2,200/-	
1.13	Cable Glands: For Safe and Hazardous Area Motors	Per Gland	
	Double Compression Gland		
	(a) Frame 56 to 80 (Star connected)	Safe Area: Rs. 1,300/- Hazardous Area (80 frame): Rs. 1,300/- (Only single run can be given in these frames)	
	(b) Frame 90 to 132	Safe Area: (2Run) Rs. 1,300/- per gland Hazardous Area: (1Run) Rs. 1,500/- per gland	
	(c) Frame 160 to 225 - DOL (2Runs)	Safe Area: Rs. 2,400/- Hazardous Area: Rs. 2,800/-	
	(d) Frame 250 to 315 - DOL (2Runs)	Safe Area: Rs. 3,800/- Hazardous Area: Rs. 4,800/-	
	(e) Frame 355 to 450: DOL (2Runs)	Safe Area only: Rs. 4,500/-	
1.14	Provision for fitment of external brake On NDE side (e.g. EMCO): Providing Brake mounting arrangement only (without brake)	15% Upto frame 200	
1.15	Low Vibration -IS 12075:2008 / IEC 60034-14:2007		
	(a) Reduced Vibration	10%	
	(b) Special Vibration	20%	

CASH EXTRAS FOR ADDITIONAL FEATURES

Sr. No.	FEATURES	Cash Extras / Percentage Extra
1.16	Bearings	(Online Greasing Arrangement is standard feature in motors where Roller bearings are used)
	(a) Roller Bearing at DE Side in place of ball bearing	
	(i) Frame 112 & 132 (pre-greased, no OLGA provided)	Rs. 1,800/-
	(ii) Frame 160, 180	Rs. 1,800/-
	(iii) Frame 200	Rs. 3,500/-
	(iv) Frame 225 to 250	Rs. 5,000/-
	(v) Frame 280 to 315	Rs. 7,000/-
	(vi) Frame 355	Rs. 14,000/-
	(vii) Frame 400	Rs. 21,000/-
	(viii) Frame 450	Rs. 31,000/-
	(b) Hybrid Bearing	
	(i) NDE - Frame 132	Rs. 13,000/-
	(ii) NDE - Frame 160-180	Rs. 15,700/-
	(iii) NDE - Frame 200-225	Rs. 17,500/-
	(c) Insulated Bearings	
	(i) NDE - Frame 250, 280, 315	Rs. 33,600/-
	(ii) NDE - Frame 355, 400	Rs. 47,000/-
(iii) NDE - Frame 450	Rs. 85,000/-	
1.17	Other Miscellaneous Features	
	(a) One size Higher T Box	(for fr 132 & 160: 4%); for all other frames it is 2%
	(b) Cast Iron T Box	2%
	(c) C I Fan (where plastic fan is standard)	2%
	(d) S.S. Hardware (only for safe area motors)	2% with maximum Rs. 4,000/-
	(e) Seaworthy / export packing case for home market (Without fumigation certificate)	5% subject to Rs. 6000/-
	(f) Longer Flying leads (length not exceeding 1.5mtr)	2.5% subject to max. Rs. 5,000/-
	(g) Longer Flying leads (length exceeding 1.5mtr and less than 3m)	3% subject to max. Rs. 7,500/-
	(h) Extra Name Plate / Tag Plate	Rs. 400/-
1.18	Miscellaneous Mechanical Features:	
	(a) Direction Arrow Plate	Rs. 400/-
	(b) Spreader box (frames 180-315 Frame) for safe area Motors	2%
	(c) On Line Greasing Arrangement	For Safe Area: Frame 160 to 200: Rs. 1,250/- For FLP & Ex'nA': Frame 180 to 200: Rs. 1,250/-
	(d) SPM Nipples provision: for safe area motors (for 250 frame onwards)	2% subject to Rs. 5,000/-
	(e) High Temperature Grease (Molykote HP 300) (For other grade High Temperature Grease, refer to Sales Office)	Fr 63 to 100: Rs. 800/-
		Fr 112 to 160: Rs. 1,600/-
		Fr 180 to 280: Rs. 11,000/-
(f)	Fr 315 to 355: Rs. 19,000/-	
3, 4 cable Run T Box	Fr 400 to 450: Rs. 49,000/-	
	5% For 355 Frame and above	
1.19	Motor with Fabricated body	15%

CASH EXTRAS FOR ADDITIONAL FEATURES

Sr. No.	FEATURES	Cash Extras / Percentage Extra
1.20	Flameproof Motors with ATEX, IECEX approval	10% over LP of FLP motor of respective efficiency level.
1.21	Cash Extra for Atex Approved Space Heaters	112 & 132 : Rs. 5380/-
	Cash Extra for Atex Approved Thermistors (3Nos.)	160 & 225 : Rs. 6110/-
1.22	Motors suitable for Zone 21 / Zone 22	Rs. 3800/-
1.22	Motors suitable for Zone 21 / Zone 22	Refer Sales Office

CASH EXTRAS FOR ADDITIONAL FEATURES

Sr. No.	FEATURES	Cash Extras / Percentage Extra
2.00	ELECTRICAL FEATURES	
2.01	Base voltage between 250 -550 V	
(a)	415 V, 50 Hz	Nil
(b)	Non Standard Voltage 220 / 550 V, 50Hz / 60Hz	5%
(c)	Dual voltage with 1:2 ratio example 220/440V	5%
2.02	Insulation Class 'H' (DC wire and VPI is standard feature for motors with H class insulation)	10%
2.03	Thermistors / Thermostats (90 Frame onwards)	
(a)	Set of 3 nos PTC Thermistors without controller	Rs. 2,400/-
(b)	Set of 6 nos PTC Thermistors without controller	Rs. 4,800/-
(c)	Thermostats per unit	Rs. 600/-
2.04	Multispeed Motors (safe area only)	
(a)	Single tapped winding upto 8 pole	10% over IE2 safe area
(b)	Dual speed with separate winding or polarity above 8 pole	17.5% over IE2 safe area
(c)	Motors single speed with 10, 12, 16 Poles	15% over IE2 safe area
2.05	Intermittent Duty Motors (for motors other than standard MC series)	10%
2.06	RTD: (safe area only)	
(a)	RTD (Simplex: 3 nos: 1 per phase): for safe area 250 frame and above;	Rs. 6000/-
(b)	However it is a standard for DCCA motors.	
(c)	RTD (Simplex: 6 nos: 2 per phase): for safe area motors	Rs. 10,000/- 250 frame onwards (Not for hazardous area motors)
	RTD (Duplex: 3 Nos: 1 per phase): for safe area motors	Rs. 12,000/- 250 frame onwards (Not for hazardous area motors)
	RTD (Duplex: 6Nos: 2 per phase): for safe area motors	Rs. 24,000/- 250 frame onwards (Not for hazardous area motors)
2.07	BTD (safe area only)	
(a)	BTD: Simplex: 2 nos for safe area 250 frame and above; However it is a	Rs. 7,000/-
(b)	standard feature for DCCA motors.	
(c)	BTD: Duplex: 2 nos for safe area Frame 250 and above	Rs. 9,000/- Frame 250 onwards (Not for hazardous area motors).
3.00	OTHER CHARGES	
3.01	Routine Testing	
(a)	Frame 63 to 132	Rs. 2,200/-
(b)	Frame 160 to 225	Rs. 3,500/-
(c)	Frame 250 and above	Rs. 5,000/-

CASH EXTRAS FOR ADDITIONAL FEATURES

Sr. No.	FEATURES	Cash Extras / Percentage Extra
3.02	TYPE Test	
	(a) Frame 63 to 132	Rs. 5,500/-
	(b) Frame 160 to 225	Rs. 10,000/-
	(c) Frame 250 to 315	Rs. 14,000/-
	(d) Frame 355 and above	Rs. 16,000/-
3.03	Combined Testing for both Safe and Hazardous Area Motors in presence of approved test house	
	(a) Frame 63 to 132	Rs. 1,60,000/-
	(b) Frame 160 - 225	Rs. 1,75,000/-
	(c) Frame 250 - 315	Rs. 1,80,000/-
	(d) Frame 355 and above	Rs. 2,00,000/-
	(e) Motor testing with Inverter Drive (Safe Area)	Rs. 60,000/- With BBL certification only.
3.04	Noise and Vibration Test	
	(a) Frame 63 to 132	Rs. 750/-
	(b) Frame 160 to 225	Rs. 800/-
	(c) Frame 250 and above	Rs. 1,000/-
3.05	(a) Shaft UT Test (per unit)	Rs. 2,500/- Minimum charge for this test will be for Rs. 7500/- i.e it is for min 3 nos shafts; For any quantity more than 3 nos the said charge will apply.
	(b) Shaft DP or LPT Test (per unit)	Rs. 5,000/- Minimum charge for this test will be for Rs. 10000/- i.e it is for min 2 nos shafts; For any quantity more than 2 nos the said charge will apply.
3.06	Body DP or LPT Test	Rs.7,000/- Minimum charge for this test will be for Rs. 14000/- i.e it is for min 2 nos; For any quantity more than 2 nos the said charge per motor will apply.
3.07	Documentation Charges (Technical/Commercial)	Per Rating
	(a) Documents for approval / submission	Rs. 1,600/-
	(b) Reproducible tracing copies for final submission	Rs. 5,800/-
	(c) Marine Motors' documentation	Rs. 15,000/-
3.08	Longer Core length	10%

Cash Extra Price Calculations.

a) Wherever cash extras are in percentage please add to the list price and then apply discount.

b) Where cash extras are in absolute values please add them to the discounted net price i.e. after applying the discount.

(No discount applicable on absolute values)

*GST extra as applicable at the time of delivery.

ALL INDIA SERVICE NETWORK

- Regional Offices
- 🏭 Works
- Authorised Service Centre: Motors
- ✂ Service Centre: Servo Motors



REGIONAL OFFICES

- Mumbai** T: +91 22 6145 7200
- Pune** T: 7410011272 / 7410011271
- Ahmedabad** T: +91 79 6604 9200
- New Delhi** T: +91 11 2581 6931 / 6932 / 6933
- Indore** T: +91 731 2524 474 / 2514 486
- Ludhiana** T: +91 161 2775 692 / 93
- Jaipur** T: +91 141 2377 223
- Kolkata** T: +91 33 2443 2368 / 2382 / 2383
- Bengaluru** T: +91 80 2559 2646 / 2137 / 2681
- Chennai** T: +91 44 2815 4794 / 4793
- Secunderabad** T: +91 40 2780 1791 / 2781 4512
- Coimbatore** T: +91 422 4204314

For any enquiries please write to motorlvsales@bharatbijlee.com

BB ServiceLINE™ +91 22 - 2763 7290 | serviceline@bharatbijlee.com
 Customer Service Helpdesk for Industrial Systems



REGISTERED OFFICE
 Electric Mansion, 6th Floor,
 Appasaheb Marathe Marg,
 Prabhadevi, Mumbai 400 025
 T: +91 22 2430 6237 / 6375
 E: info@bharatbijlee.com
 CIN: L31300MH1946PLC005017

WORKS
 No. 2, MIDC Thane-Belapur Road, Airoli,
 Navi Mumbai 400 708
 T: +91 22 2763 7200 / +91 22 2760 0401

www.bharatbijlee.com

Product improvement is a continuous process and technical information herein is subject to change.